

Design considerations of concrete versus timber for domestic floors

In these days of smaller sites and restrictive planning regulations, the floor height above ground level has become critical to the overall design process.

In general terms, the N.Z. Building Code allows for a minimum floor height above ground level (if paved) of 150mm.

In the case of a concrete floor, this can be simply achieved

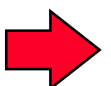
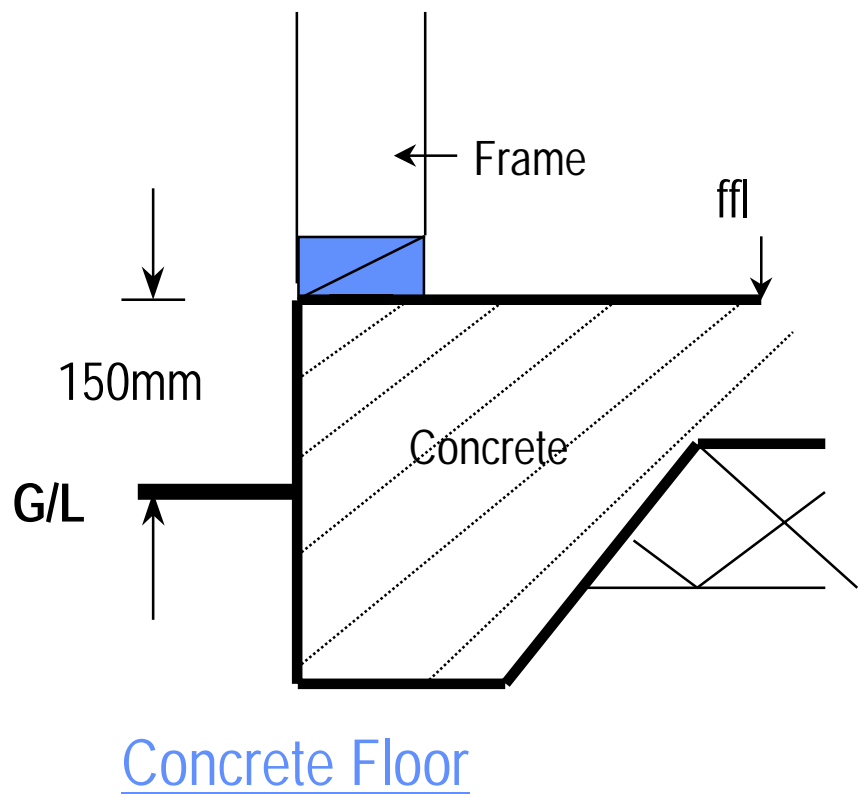

In the case of a timber floor, this cannot be realized - due primarily to the code requirement for a 450mm crawl space, below the floor, to allow for timber inspection.

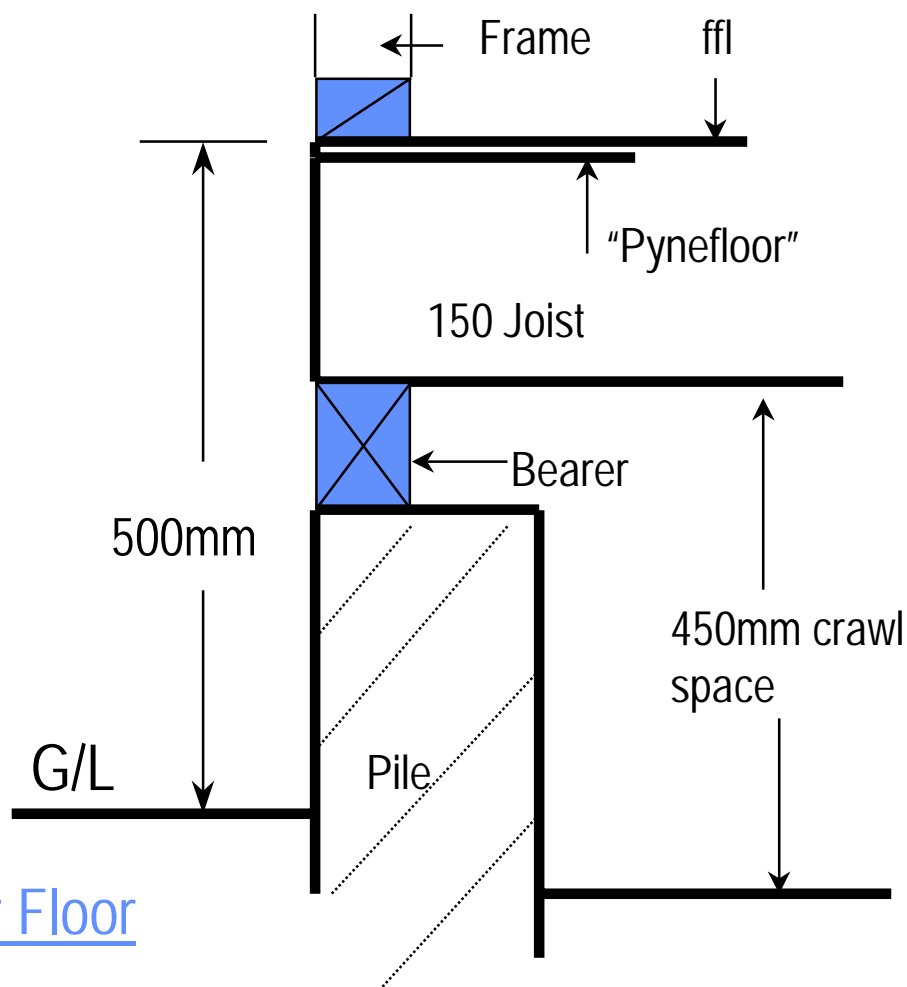

Timber Floor

For all practical purposes, the minimum achievable is 500mm.

There is one advantage - that of more clearance against possible flooding.

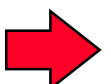

The significance of this becomes clear if we look at the application of the planning regulations of a typical “district scheme”.

Let us assume a total height limit of 8m and a “height to boundary” requirement of 2.5m, at the boundary, then 45 degrees

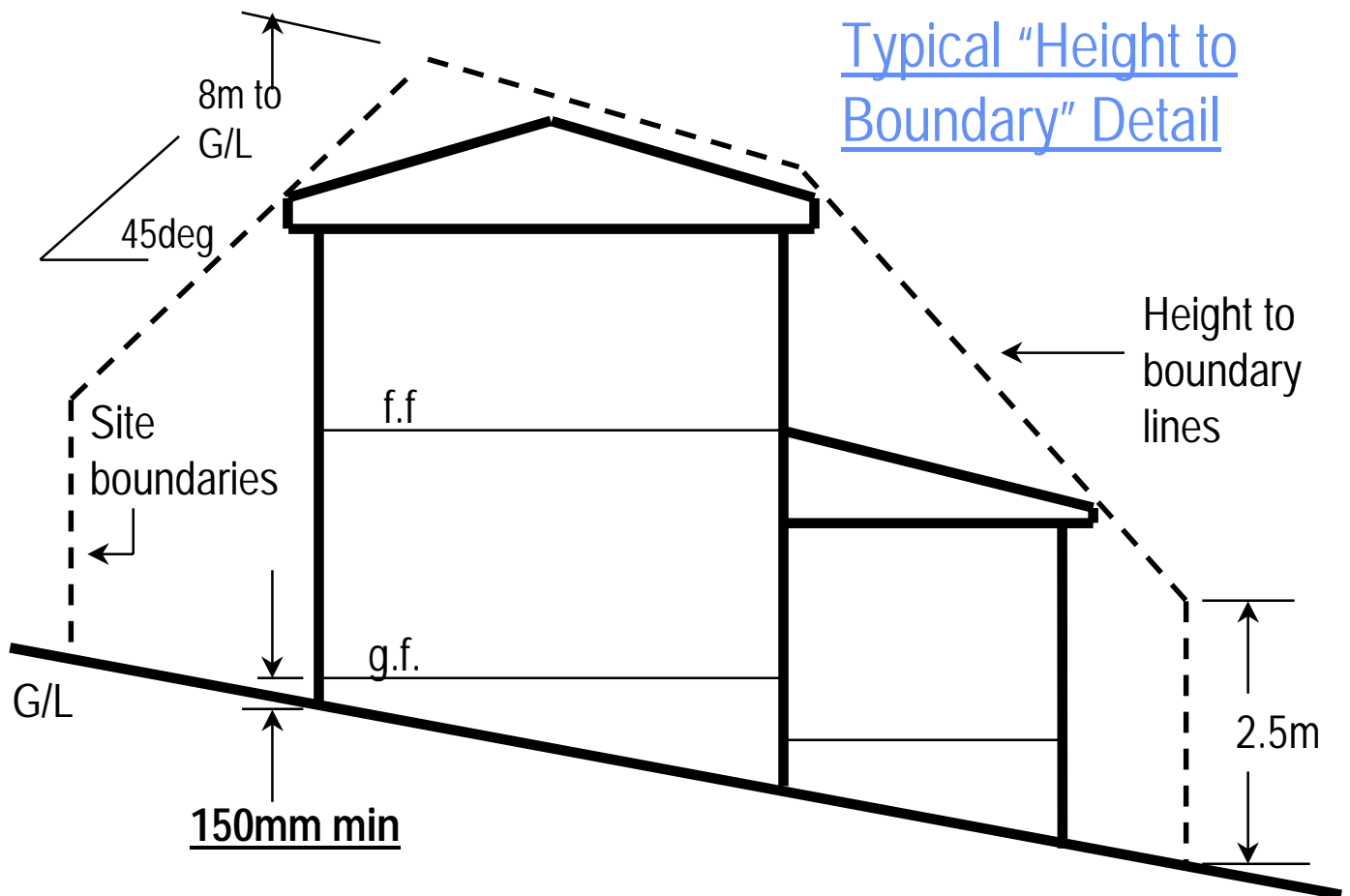

It will be seen that the closer to the ground, the larger the building can be - hence, the concrete floor is perceived to have a **350mm** advantage.

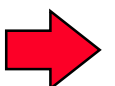

Is the 150mm ground to floor level achievable for a timber floor?

In the case of a flat site and within current regulations, it is not possible.

However, once the site is sloping, the use of “cut” together with well designed construction details can achieve a very satisfying solution.

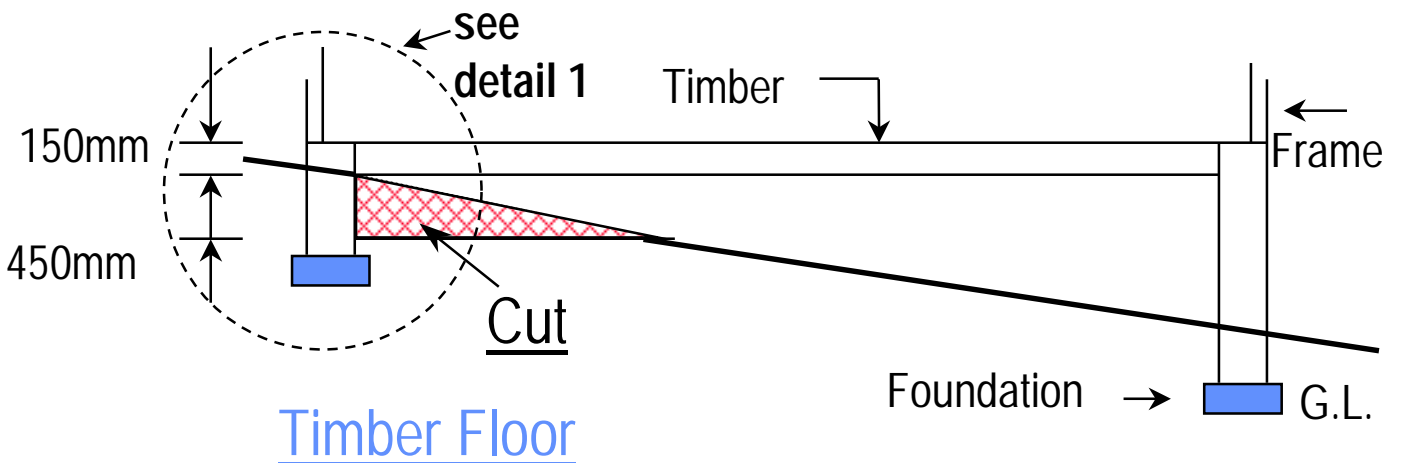
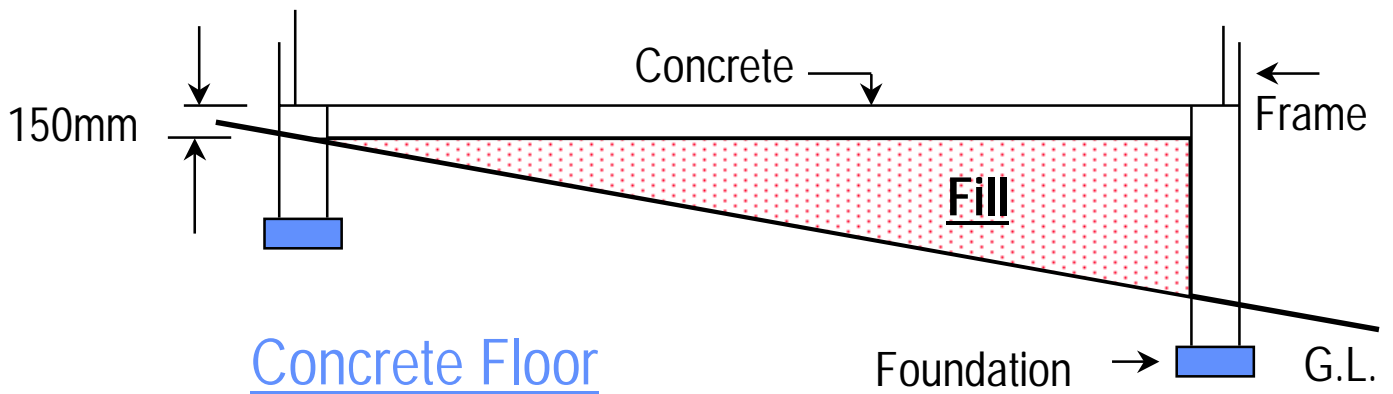

In the example shown, sub floor ventilation can still be achieved on three sides of the base, which will give adequate cross ventilation. The use of solid retaining adjacent the cut will enable the required crawl space and allow for joist support, if required.

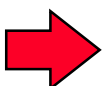

Detail 1

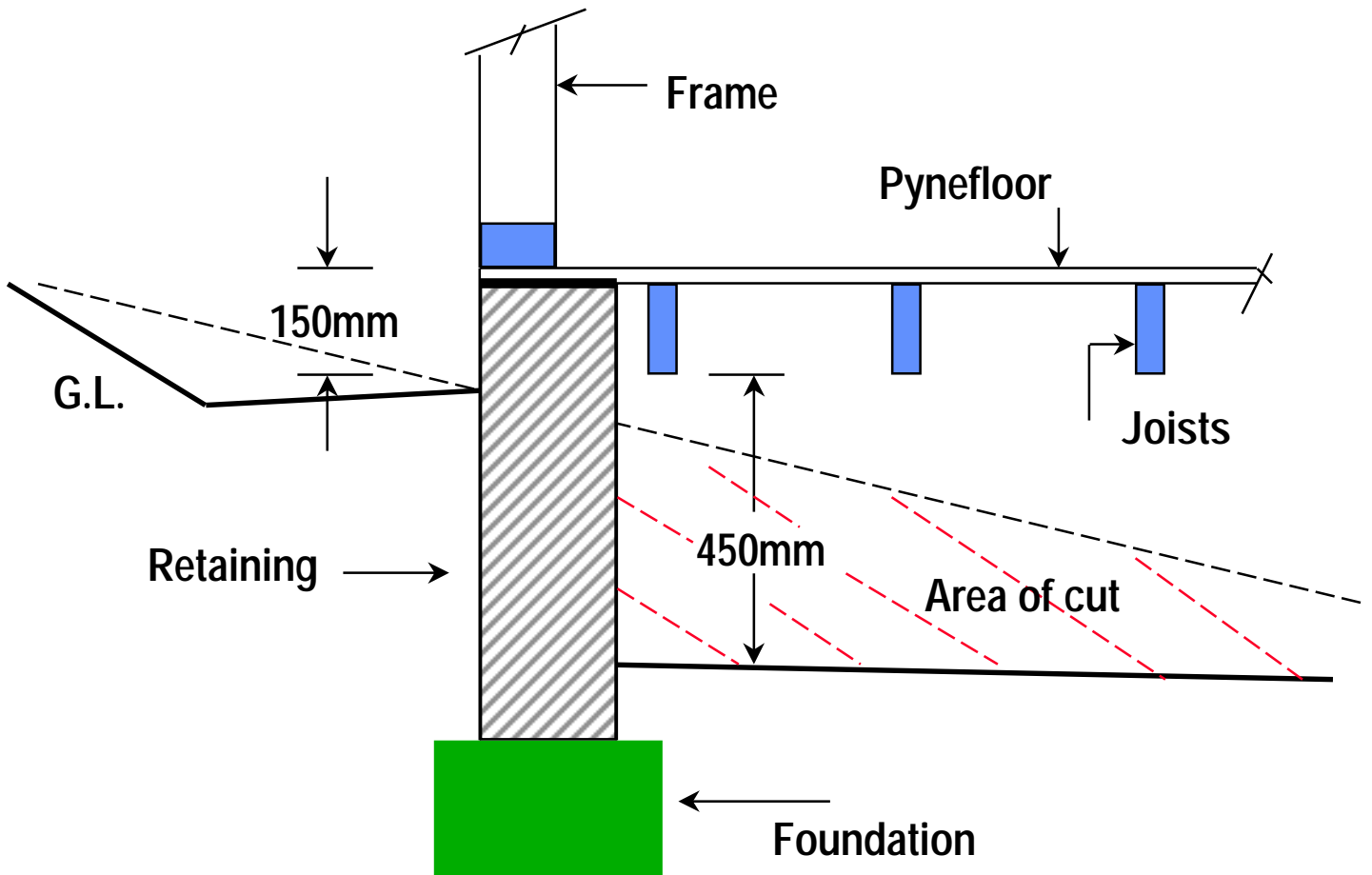

The angle at which the design process becomes practical, will of course, vary from site to site, depending on particular conditions, client requirements and space layout considerations.

In general terms, once the slope becomes greater than 7.5 degrees then the process is worth consideration.

All that “fill” and “compacting” will not be needed.

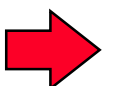



In FWPs first edition of *“Definitely Wood”* the cost of concrete versus timber was highlighted in the article by BRANZ economist - Ian Page

His conclusion was that on *“sloping sites timber floors can be cheaper”*. Once the slope is over 6 or 7 degrees the exercise is worthwhile

Having now shown that the design process can overcome the planning restrictions - this, combined with the cost savings, makes the timber floor an attractive and practical solution.

Those inherent advantages of timber floors remain and add to the total package -

- *Can be relocated*
- *Easily altered*
- *“Soft” underfoot*
- *Accessible for services*
- *Nailed direct (no bolts)*
- *Unrestricted site access (no pumps)*
- *Continuous process (no curing)*